

ALIGNMENT PITFALLS - HOW TO IDENTIFY AND ELIMINATE THEM

by

Robert D. Skeirik

Vibration Group Marketing Manager for
Computational Systems, Inc
Knoxville, Tennessee

ABSTRACT

In theory, machine alignment is a straightforward process, but in real world applications, it is often compounded by structural faults such as 'soft foot', piping strain, induced frame distortion, excessive bearing clearance or shaft rubs. These pitfalls can turn a simple job into an all day affair - frequently with unsatisfactory results despite a conscientious effort and a considerable investment in manpower and downtime. This paper will examine how to eliminate some of the typical reasons why alignments are unsuccessful.

INTRODUCTION

In theory, machine alignment is a very straightforward process. With some type of measuring device extended across the coupling, the shafts are rotated to several positions (at least three) to determine the relative position between them. Since alignment is an iterative process (meaning that the misalignment should continuously decrease with each machine move), it is theoretically only a matter of sufficiently repeating alignment corrections until an acceptable solution is achieved. In fact, quality alignment is not dependent on the type of measurement system used. Any good dial indicator set or laser system should be sufficient to perform quality alignments. Therefore, in heavy industrial applications, where the cost of downtime can be in excess of \$10,000 per hour, the fundamental question for an alignment program is not simply:

“Can I successfully align the machine?”

but rather:

“Which method will provide the fastest alignment solution so that I can start production again?”

Furthermore, since misalignment is often compounded by structural faults such as 'soft foot', piping strain, induced frame distortion, excessive bearing clearance, shaft rub, etc., it may not be possible to align the machine without first addressing these additional problems. These pitfalls can turn an otherwise simple alignment job into an

all day affair - frequently with unsatisfactory results despite conscientious effort and a considerable investment in manpower and downtime. For this reason, it is crucial for the personnel performing alignments to be aware of the kinds of structural faults that can complicate the alignment process and that they learn to recognize the tell-tale signs of bad measurements *before* they invest valuable downtime in an unproductive exercise. This paper will examine several of the most typical reasons why bad alignment measurements are obtained, how to identify them, and finally how to eliminate them.

COLLECTING VALID DATA

Some fairly simple yet powerful techniques can be applied to determine the validity of alignment readings before investing time executing a machine move that may be wrong. If using a dial indicator set, it is useful to apply the data validity rule to each set of readings. The data validity rule shown in Equation 1 compares the readings taken at the four cardinal positions:

$$\text{Top} + \text{Bottom} = \text{Left} + \text{Right} \quad (1)$$

It provides a quick way to determine the validity of an alignment solution before moving the machine.

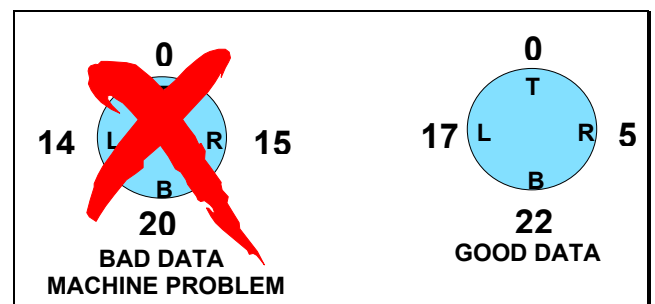

Figure 1: Examples of good and bad alignment data

This simple check is able to catch many set-up errors and mechanical faults such as ⁽¹⁾:

- loose brackets
- sticking indicators
- indicators set too high or too low

- improperly recorded data values and/or signs
- sleeve bearing float
- surface irregularities or eccentricities
- excessive bearing clearance

Small deviations from the validity rule are to be expected. If the difference is more than 10%, it is possible that the coupling may be loose enough to provide excess torsional play (“backlash”). To reduce the effects of torsional play keep the coupling engaged while rotating the shafts from the driven machine in the normal direction of rotation.

If the error is greater than 20%, the cause should be determined. This could be a problem with the alignment fixture(s) or a concern with the machine being aligned. Alignment problems occur from loose fixtures or improper use of fixtures. Possible machine concerns include locked couplings, spalled bearings, machine binds, etc. If the data validity rule is not checked when such a problem exists, these potential machine faults will remain undetected and substantially complicate the alignment process. Even worse, the objective of increasing machine reliability through quality alignment will not be accomplished. (2)

When using a laser alignment system, the potential for user error is greatly reduced due to the automatic measurement and recording of readings. However, the data validity rule can still be very useful to identify structural faults such as excessive bearing clearance and other forms of structural looseness. To apply the validity rule with a laser system, it is necessary to record ALL FOUR cardinal readings (top, bottom, left, right) and plug them into the formula. If, however, the alignment solution is based on only three of the four cardinal readings, the user will not have the ability to check the validity of the solution. In one such example involving a feed water pump in a power plant, an alignment was attempted using only three of the four cardinal measurements (top, left and right - the bottom reading was omitted). The machine was moved as indicated by the laser system but no improvement in the alignment condition was achieved. Numerous readings and machine moves were implemented but failed to result in any improvement in the alignment condition. When manually collected the reading for the fourth position (on the bottom) and plugging the values into the equation, it was clear that the validity rule was being violated. Visual inspection of the machine train indicated that one of the feet on the gearbox had been bolted down with the wrong size bolt head - thereby substantially reducing the hold-down force at this foot. This allowed the foot to lift slightly during shaft rotation creating substantial error in the readings. After replacing it with the proper size bolt, the operator was able to align the machine in just a few moves. (Note: more advanced systems are currently available that will automatically apply the validity rule to the obtained readings and indicate

whether acceptable levels for deviation have been exceeded.)

SWEEP TECHNOLOGY

The above example demonstrates the power of applying the validity rule, however, it is not always possible to obtain readings at all four cardinal positions. In such cases, alternative measurement techniques must be applied. For instance, laser alignment systems are now available that can calculate the misalignment based on a full or partial shaft rotation. These sweep systems make use of internal inclinometers to automatically collect required readings during shaft rotation and then mathematically calculate the misalignment. For a machine in good working order, the sweep curve will look like a perfect sine wave. Figure 2 shows examples of sweep curves for machines with various mechanical conditions.

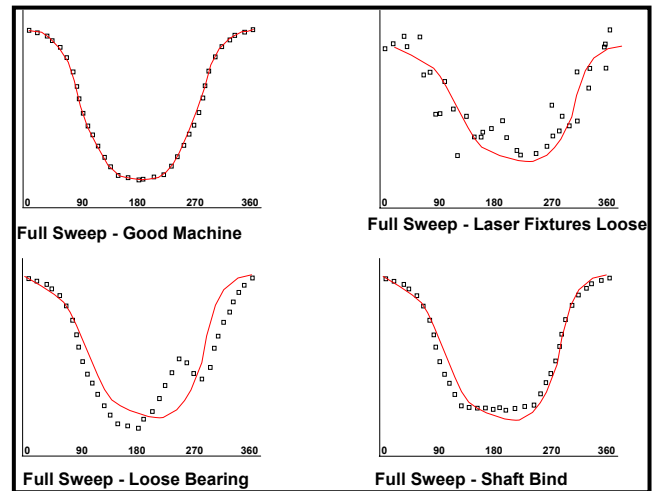

Figure 2: Examples of sweep curves

Such systems are even able to calculate a correction with as little as 35-70° of rotation by extrapolating the remainder of the shaft rotation (see Figure 3).

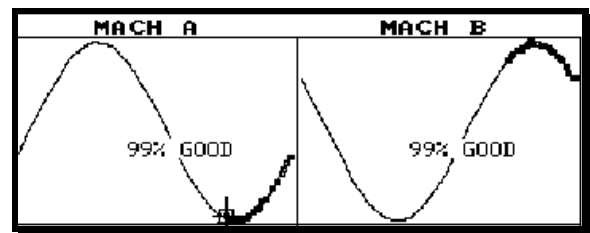

Figure 3: 70° sweep showing extrapolated calculation of full shaft rotation

While this approach has now made it possible to accurately measure machinery misalignment in applications that were previously untouchable with dial

indicators or even conventional laser alignment equipment, it does not necessarily address the issue of data validity. In fact, even with a sweep measurement, it is impossible to verify data validity based on only three measurement points. To fully utilize the potential of the sweep technology, it is advisable to collect a large number of readings over as large a sweep angle as possible - a simple requirement to fulfill as advanced sweep systems automatically collect data as often as every degree during shaft rotation. The only requirement of the user is to rotate the shaft smoothly through whatever portion is accessible. With as little as 12 readings collected over one half of a shaft rotation (180°), it is now possible to apply statistical sampling techniques to automatically determine the validity of the data.

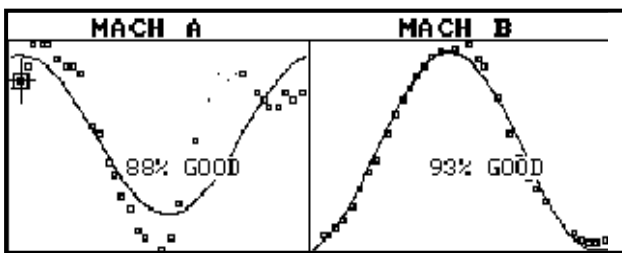

Figure 4: Sweep data for motor/pump pair

Figure 4 shows sweep data for a motor/pump pair where the readings on the pump (Machine B) show high data validity, while the readings on the motor (Machine A) show clear signs of structural damage and a correspondingly lower confidence level as determined by the automatic statistical processing. In fact, Machine A had excessive internal looseness due to a developing bearing fault. In this case, however, the user chose to ignore the warning from the data validity graph and proceeded with the job. The bearing did not prevent him from completing the alignment, but it did require him to make several extra moves and to use hours of precious downtime to bring the misalignment into acceptable levels. Ironically, the motor bearing failed two days after start-up, so the user was faced with a much larger maintenance task and repeated installation and alignment just a few days later.

The information provided by the sweep method of alignment is both powerful and conclusive. When performed with a dual laser system, the sweep actually distinguishes between faults on Machine A and Machine B. Furthermore, the shape of the sweep curve can often be used to determine the nature of the machine fault. The 'double hump' curve in Figure 4 is indicative of structural looseness. This could be either a damaged bearing or a problem with an unsecured machine foot. Another

mechanical problem that frequently can be diagnosed from the sweep curve - when present - is a shaft bind.

BUILDING ON GOOD FOUNDATIONS

Another major pitfall in real world alignment occurs when there is a gap between a machine foot and the foundation (so called "frame distortion" or "soft foot"). The machine frame will actually distort from its resting position as the hold-down bolts are tightened to secure the machine in place. This distortion puts the shaft in a bind and pre-loads the bearings (Figures 5a - 5c).

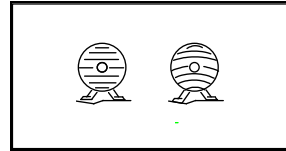

Figure 5a: Soft foot creates stress lines in the frame as a short foot is pinned to the foundation by the hold down bolt

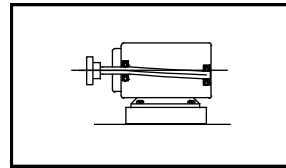

Figure 5b: Internal bearing misalignment creates substantial pre-loading on the bearing.

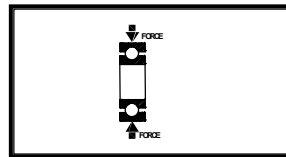

Figure 5c: Pre-loading on the bearings is one of the leading causes of premature bearing failure

A classic example of soft foot - like the bar table with one short leg - occurs when the machine naturally rests on three legs and the fourth leg is short. If not properly corrected before beginning the actual alignment, it may be difficult, even impossible, to achieve acceptable results.

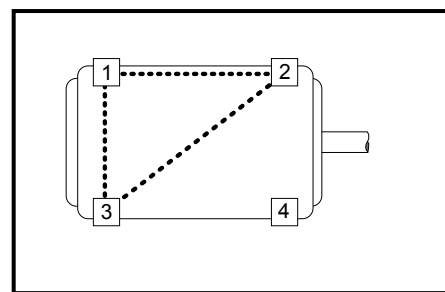

Figure 6: Machine with one "soft foot"

The technician may implement the exact machine move as required by the alignment calculation, only to find that the frame distorts when he tightens down the hold down bolts. Verification measurements may show little or no achieved improvement. In addition to the direct impact on alignment, the frame distortion resulting from a soft foot can also lead directly to unnecessary vibration and

premature component failure. In fact, soft foot has been observed to increase machine vibration levels by as much as ten times. In such cases, by not recognizing the contribution made by the soft foot, the technician may have tried to lower the vibration levels by better balancing, better alignment and so on - but obtained very little improvement⁽³⁾.

These facts clearly establish that a soft foot check is a vital part of the pre-alignment process. Unfortunately, due to misconceptions and pressure from production to get "back on line", it is still viewed as an unnecessary or expendable step in many plants today.

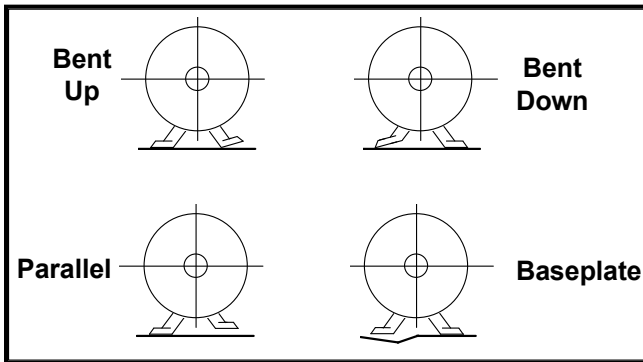

Figure 7: Common Types of Soft Foot

One must also understand that there are different types of soft foot. In its simplest form, a foot can either be parallel or bent (Figure 7). It is relatively simple to locate and correct for a parallel foot. It is substantially more complex to determine the profile of and correct for a bent foot.

The traditional way to locate a soft foot is by installing a dial indicator on the foot and watching the movement as you loosen the hold down bolt (Figure 8). This approach works fairly well in the case of a parallel foot but may give an incorrect indication of bent foot.

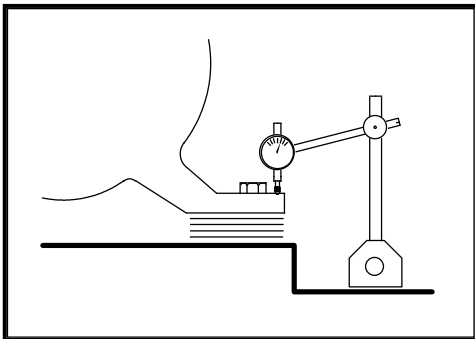

Figure 8: Usage of dial indicator for soft foot

More recently, lasers have also been used to locate soft foot. There are two basic methods of checking soft foot with a laser that measure different parameters and have fundamentally different goals: Frame Distortion Index and the Laser Soft Foot Locator. In each case, the lasers are mounted on the machine shaft on either side of coupling and live readings are taken while individual hold down bolts are loosened and tightened. As the name suggests, the goal of the Frame Distortion Index method is to determine the total amount of frame distortion that occurs due to a soft foot. In contrast, the goal of Laser Soft Foot Locator is to locate potential soft foot problems and quantify whether the problem must first be addressed in order to be able to successfully complete the alignment job. As such, the goal of the Laser Soft Foot Locator is to provide the technician with the recommended approach for the "quickest path back to production".

Frame Distortion Index

The Frame Distortion Index (FDI) measures the vertical movement of the machine shaft caused by loosening any individual hold down bolt. The calculation is listed below in Equation 2.

$$\text{Frame Distortion Index} = 2(Y)(\text{FB}) \quad (2)$$

Where: Y = Vertical angularity of laser beam
 FB = Distance between front and back feet

This calculation is based on an old millwright's rule of thumb but replaces the traditional dial indicator with a set of laser fixtures. The result is a numerical value that quantifies the movement of the shaft. This value does not,

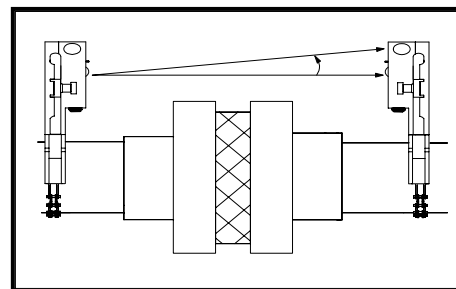

however, correlate directly to the actual movement of the machine foot.

Figure 9: Measurement of vertical shift ("Y"):

$$Y = (\text{vertical shift in laser}) / (\text{distance between laser fixtures})$$

Therefore, the user must firmly resist the temptation to use this value as a shortcut to determine the appropriate shim correction for that foot. "[FDI] cannot distinguish between shaft movement caused by a bent foot and the shaft movement caused by a parallel airgap. Yet the two

types of soft foot must be corrected entirely differently... [FDI] does not produce suggested soft foot corrections. The source of the soft foot must be determined by analysis before corrections are made.”⁽⁴⁾ Existing convention dictates that a machine foot is soft if the FDI is above 2-3 mils (50-75µm).

Laser Soft Foot Locator

The Laser Soft Foot Locator, a more recently developed method for quantifying soft foot, focuses specifically on the effect of the soft foot on the technician’s ability to successfully complete the alignment task. This advanced procedure can no longer be performed with dial indicators. In contrast to FDI, which only looks at the vertical lift of the shaft, the Laser Soft Foot Locator now looks at the total movement of the shaft - both vertical and horizontal. Total angularity equals the vector sum of the vertical angularity “Y”, as used in the FDI calculation, plus the horizontal angularity “X”. The total angularity is calculated for each machine shaft separately and the greater of the two values is used. For this reason, a dual axis, dual laser system is required to implement this procedure. The resulting measurement represents the theoretical maximum possible misalignment that could be induced at the coupling due to this “soft foot”. Established convention dictates that a machine foot is soft if the resulting shift in angularity is more than 0.5 mils/in (or 0.5 mrad), however, the Laser Soft Foot Locator method does not express the results numerically. Instead, the result is expressed as a priority, or level of urgency, using symbols that provide the technician with a recommended course for the “quickest path back to production” with the machine in acceptable operating condition. The results of the Laser Soft Foot Locator and their interpretations are listed in Table 1.

Table 1: Laser Soft Foot Locator Results

Reading in (mils/in)(mrad)	Result	Interpretation
0.0 – 0.5	OK	Machine in good condition; conscientious effort should achieve excellent alignment condition.
0.5 – 1.0	X	Soft foot is present; may not be able to achieve or maintain excellent alignment condition.
1.0 - 1.5	XX	Substantial soft foot is present; may not be able to achieve or maintain acceptable alignment condition. Correct soft foot first if machine is critical or must run for an extended period before next shutdown.
	XXX	Serious soft foot is present;

> 1.5		don’t waste time trying to align machine unless you have first corrected the soft foot.
-------	--	---

Soft Foot Correction

Regardless of the method used to locate a soft foot on the machine, it is always required to actually measure the gap (size and shape) between the foot and the foundation. This is necessary to determine whether the soft foot is parallel or bent as well as verifying that the foundation is level. With a parallel soft foot, the correction typically involves inserting one or two shims. In the case of a bent foot or uneven foundation, the technician will need to create a “step shim” or “shim pack” to completely fill the gap (Figure 10).

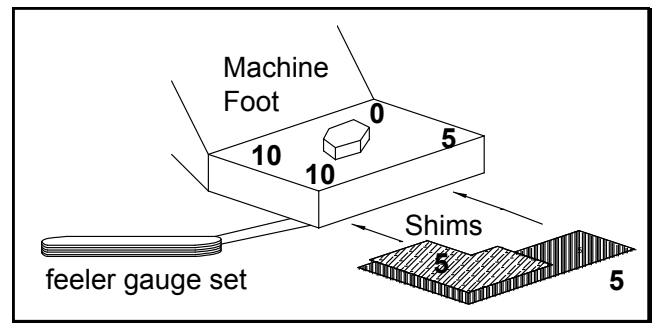

Figure 10: Measure soft foot with feeler gauge and fill gap completely

OTHER STRESS FACTORS IN ALIGNMENT

Another structural condition that can effect the alignment and the running condition of your machinery is piping strain (often referred to as “induced soft foot”). Piping strain occurs when the pipe or conduit does not mate up to within 2 mils (50µm) of the flange. This condition can create equally damaging stress lines and bearing pre-loads as the conventional soft foot described above. However, in contrast to conventional soft foot, piping strain is equally likely to move the machine vertically or horizontally. This makes the Laser Soft Foot Locator method the preferred approach for quantifying piping strain.

SUMMARY

It is important to realize that otherwise straight-forward alignment jobs can become highly complex and yield unacceptable results if the technician does not address the quality of the alignment measurement and potential frame stress conditions (frame distortion, soft foot, and piping strain) during the pre-alignment check. These steps should all be conducted before the technician ever begins to move the machine.

Data quality can be determined by using the validity rule for conventional dial indicator and laser alignment

methods, while sweep laser system offer an added level of data qualification by measuring the shaft movement throughout the entire rotation. This added information could help identify not only the existence of a structural problem but also the nature of the problem.

Soft foot and piping strain can be quantified using either the Frame Distortion Index (FDI) or the Laser Soft Foot Locator. FDI looks at the total stress or distortion on the frame caused by vertical movement of the shaft, while the Laser Soft Foot Locator looks at both the vertical and horizontal movement to quantify the need (priority) to fix soft foot before proceeding with the alignment job.

References

- (1) Murray, M.G., Alignment Manual for Horizontal, Flexibly-Coupled Rotating Machines, p. 46A, Murray & Garig Tool Works, Baytown Texas (1983).
- (2) Nower, D.L., Multiple Data Acquisition Techniques for Shaft Alignment, pp. 2-3, Computational Systems, Inc., Knoxville, Tennessee, (1996)
- (3) Buscarello, R.T., Practical Solutions to Machinery and Maintenance Vibration Problems, pp. 99-105, Ralph T. Buscarello, Lakewood, Colorado (1979)
- (4) Evans, G. and Casanova, P., The Optalign Training Book, p. 72, Ludeca, Miami, Florida (1990)

Presented at Vibration Institute, New Orleans, June 17th, 1997